

**Check list to evaluate the Capability of bidders qualifying for price bid opening:**

Sl.No	Description / Requirement from the tenderer	Tenderer's response should be clear, firm, complete & legible. If necessary, separate sheet shall be used.
1.	Name & Complete address of the tenderer with contact details:	
2.	Details of EMD (should be in the form of DD) Demand draft No. Amount Rs.1,50,000/- Bank details:	
3.	NSIC or MSME Registration No: Company Name & Address: Validity : Product for which registered:	
4.	Status of the tenderer: Proprietorship / Partnership / Private Limited. / Public Limited	
5.	Details of Contract Registration with Govt. depts. Class and value (If available)	
6.	Details of PAN	
7.	Employees provident fund Registration:	
8.	Employees State Insurance Registration:	
9.	GST Registration No: 05 Last GST Returns filled – Att Copies	
10.	Copy of Income Tax Return for the last 3 years ending 03/2024	
11.	Solvency certificate and working capital issued by schedule bank will be enclosed or Audited balance sheet certified by CA for confirmation of financial soundness.	
12.	Annual turnover certificate for last 3 years, ending on 31 <sup>st</sup> march of the previous financial year, issued by CA, along with relevant pages of audited balance sheet in support thereof.	
13.	Details of similar works executed with Govt. depts. during last 3 years	Use separate sheet to furnish complete details

**Note:** Self attested copy of relevant certificates for items 3-13 are to be enclosed.

I/We hereby certify that the information furnished above and the attached documents as proof of the information are true and correct to the best of our knowledge.

I/We understand that these details are required to decide our eligibility to participate in the tender process and opening of our price bid thereon.

I/We also authorize the Director / NITPY or his representative to approach the source of the certificate to verify our competence, if required, for processing the tender.

Dated : 2024

\_\_\_\_\_  
(Sig of Proprietor/Partner of the Firm  
alongwith stamp)

**ARMY PUBLIC SCHOOL, AMBALA CANTT**

**TECHNICAL BID**

**CONSTRUCTION OF MULTIPURPOSE SHED AT MAIN WING, ARMY PUBLIC SCHOOL,  
AMBALA CANTT**

1. Name of Firm/Contractor with full address and tele No. : \_\_\_\_\_  
\_\_\_\_\_  
\_\_\_\_\_
2. GST No of the Firm/Contractor. : \_\_\_\_\_
3. **Scope of Work.** Construction of Multipurpose Shed over assembly ground at Main wing of Army Public School, Ambala Cantt as a framed structure as per specification, dimensions and STAAD design and drawing given as per details specified and directed.

**Detailed Specifications**

4. Multipurpose shed be constructed strictly as per STAAD design & drawing duly completed in all respect as specified in STAAD. All the material to be used should be of ISI mark. Copy of the drawing is attached. (Make: Tata/Jindal ISI Mark)
5. Construction of Multipurpose Shed (180'-5" Ft x 120'-5" Ft ) having total area 21750.25 Sq Ft) alongwith civil work of pillers as per specification given in drawing duly completed in all respect at Main wing of Army Public School, Ambala Cantt. (Make: Tata/Jindal ISI Mark)
6. Complete Lighting and fans will also be installed for the lighting and high performance fans etc. for airing in the shed as per drawing att. Details are as under:-
- |   |   |     |
|---|---|-----|
| (a) Multi Power Socket 6 x 16A Outlet                       | - | 20  |
| (b) Switch Board with 5 Amp socket                          | - | 14  |
| (c) 1x4' Batton LED Luminaire (1X18W)                       | - | 24  |
| (d) Ceiling Fan heavy duty 1400MM (Industrial fans)         | - | 66  |
| (e) High beam down Lighter 150 W/100W (As per School reqmt) | - | 110 |
| (f) 8 Way Horizontal DB                                     | - | 02  |
- Make : Lights : Syska/Phillips, Fans : Havells / Crompton Heavy duty, Switch/Sockets : Havells
7. Colour of Pre painted Galvalume sheet for multipurpose shed be specified by school authorities and 10'-0" to be kept outside the dice area. Thickness of pre painted Galvalume sheet will be min 0.6 mm JSW AZ 150 (Colour option- Dark green/Blue/Red of as colour decided by the management)
8. The warranty/defect liability period of the multipurpose shed will be min 8 years after the completion of the subject work.

Proprietor/Partner of The Firm \_\_\_\_\_

9. Shelf life of the multipurpose shed will be 99 years after completion of the work and shelf life of the pre galvalumed sheet will be min 25 years after fixing on the multipurpose shed. Structural stability certificate of Multipurpose shed and shelf life certificate for the galvalumed sheed be submitted on completion of the shed before the final payment. The vendors should have to give capability certificate and demo / presentation of the material as well as construction of the multipurpose shed.

10. Certificate in r/o of the acceptance of all terms & conditions of the bid by seller will be given alongwith the tender documents. Copy of the certificate is enclosed herewith .

11. **Site Engineer.** At all time when the construction activity is going on at the site, a suitable and well qualified site engineer, with minimum qualification of Diploma in Civil Engineering, adequate work experience will be physically present. Any omission in this regard will invite payment penalty of Rs 1500/- per day. The individual details along with qualification certificate will be submitted to the Principal, APS Ambala Cantt before commencement of works at the site.

12. MSME rules and regulations , if applicable (Udyog Adhar/Udyam Adhar).- if the bidder is a Micro or Small Enterprise as per latest definitions under MSME rules, the bidder shall be exempted from the requirement of “Bidder Turnover” criteria and “Experience Criteria” subject ot meeting of quality and technical specifications. If the bidder is OEM of the offered products, it would be exempted from the”OEM Average turnover” criteria also subject to meeting of quality and technical specifications. In case any bidder is seeking exemption from Turnover/Experience criteria, the supporting documents to prove his eligibility for exemption must be uploaded for evaluation by the buyer.

13. MSME if applicable – If the bidder is start-up, the bidder shall be exempted from the requirement of “Bidder Turnover” criteria and “Experience criteria” subject to their meeting of quality and technical specifications. If the bidder is OEM of the offered products, it would be exempted from the ”OEM Average turnover” criteria also subject to meeting of quality and technical specifications. In case any bidder is seeking exemption from Turnover/Experience criteria, the supporting documents to prove his eligibility for exemption must be uploaded for evaluation by the buyer. The minimum average annual financial turnover of the bidder during the last three years, ending 31<sup>st</sup> march of the previous financial year, should be as indicated above in the bid document. Documentary evidence in the form of certified Audited balance sheets of the relevant periods or a certificate from the chartered Accountant/cost Accountant inticating the turnover details for the relevant period shall be uploaded with the bid. In case the date of constitution/incorporation of the bidder is less than 3 years old, the average turnover in respect of the completed financial years after the date of constitution shall be taken into account for this criteria.

Proprietor/Partner of The Firm \_\_\_\_\_

14. Make in india certificate to be enclosed by the bidder. Preference to make in India products (For bids <200 crore). Preference shall be given to class 1 local supplier as defined in public Procurement (Preference to make in india), order 2017 as amended from time to time and its subsequent orders/Notifications issued by concerned Nodal ministry for specific Goods/Products. The minimum local content to qualify as a class 1 local supplier is denoted in the bid documents. If the bidder wants to avail the purchase preference, the bidder must upload a certificate from the OEM regarding the percentage of the local content and the details of locations at which the local value addition is made alongwith their bid, failing which no purchase preference shall be granted. In case the bid value is more than Rs 10 Crore, the declaration relating to percentage of local content shall be certified by the statutory auditor or cost auditor. If the OEM is a company and by a practicing cost accountant or a chartered accountant for OEMs other than companies as per the Public Procurement (Preference to Make-in-India) order 2017 dated 04.06.2020. Only class 1 and class 2 local supplier as per MII order dated 04.06.2020 will be eligible to bid. Non-local suppliers as per MII order dated 04.06.2020 are not eligible to participate. However, eligible micro and small enterprises will be allowed to participate. The buyers are advised to refer the OM No F.1/4/2021-PPD dated 18.05.2023.

15. **OEM Certificate.** In case the Bidder is not the OEM, the agreement certificate with the OEM for sourcing the spares shall be mandatory. However, where OEMs do not exist, minor aggregates and spares can be sourced from authorized vendors subject to quality certification.

16. **Warranty and Maintenance Backup.** During the period of warranty, the vendor would provide System Maintenance. Vendor will provide the following :-

(a) During the period of warranty the vendor will ensure that the system continues to perform in exactly the same manner as at the time of acceptance.

(b) **Hardware Maintenance.** It will be mandatory for vendors to have service facilities. This information will be provided alongwith the **Technical Bid**. The information being provided by the vendor regarding services facilities shall be verified by a team of officers (if required). In the event of any information being provided by the vendor in his bid found to be untrue, the bids of the vendor are liable to be rejected.

(c) **Arrangements of Warranty.** Rep of firm will be available on phone call during the warranty period in any problem faced by this unit.

17. **Earliest Acceptable Year of Manufacture.** Quality / Life certificate will need to be enclosed with the Bill.

18. **Transportation.** All the stores will be delivered at the consignee address. Seller will bear the costs and freight.

Proprietor/Partner of The Firm \_\_\_\_\_

19. **Quality.** The quality of the stores delivered according to the present Contract shall correspond to the technical conditions and **ISO certified** standards valid for the deliveries of the same stores for in Seller"s country or specifications enumerated as per RFP and shall also include therein modification to the stores suggested by the Buyer. Such modifications will be mutually agreed to. The Seller confirms that the stores to be supplied under this Contract shall be new i.e. not manufactured before (**year**), and shall incorporate all the latest improvements and modifications thereto and spares of improved and modified equipment are backward integrated and interchangeable with same equipment supplied by the Seller in the past if any. The Seller shall supply an interchangeability certificate along with the changed part numbers wherein it should be mentioned that item would provide as much life as the original item. The vendor should also be committed to provide higher version of the product offered in case the offered product becomes obsolete or newer version is available without any change in the terms and conditions and prices quoted.

20. **Quality Assurance.** Seller would complete the Standard Acceptance Test Procedure (ATP) within 04 weeks from the last date of delivery of stores. Buyer reserves the right to modify the ATP. Seller would be required to provide all test facilities at his premises for acceptance and inspection by Buyer. The details in this regard will be coordinated during the negotiation of the contract. The item should be of the latest manufacture, conforming to the current reduction standard and having 100% defined life at the time of delivery.

21. **Inspection Authority.** The inspection will be carried out by PMG board of officers on behalf of the buyer. The mode of inspection will be Joint Inspection.

22. **Franking Clause.** The following Franking clause will form part of the contract placed on successful Bidder:-

(a) **Franking Clause in Case of Acceptance of Eqpts.** "The fact that the eqpts have been inspected after the delivery period and passed by the Inspecting Officer will not have the effect of keeping the contract alive. The eqpts are being passed without prejudice to the rights of the Buyer under the terms and conditions of the contract".

(b) **Franking Clause in Case of Rejection of Eqpts.** "The fact that the eqpts have been inspected after the delivery period and rejected by the Inspecting Officer will not bind the Buyer in any manner. The eqpts are being rejected without prejudice to the rights of the Buyer under the terms and conditions of the contract."

23. **Claims.** The following Claims clause will form part of the contract placed on successful Bidder:-

(a) The claims may be presented either: (a) on quantity of the stores, where the quantity does not correspond to the quantity shown in the Packing List/Insufficiency. in packing, or (b) on quality of the stores, where quality does not correspond to the quality mentioned in the contract.

(b) The quantity claims for deficiency of quantity shall be presented within 45 days of completion of „opening board of officers" and acceptance of eqpts. The quantity claim shall be

submitted to the Seller as per Form DPM-22 (Available in MoD website and can be given on request).

Proprietor/Partner of The Firm \_\_\_\_\_

(c) The quality claims for defects or deficiencies in quality noticed during the JRI shall be presented within 14 days of completion of JRI and acceptance of eqpts. Quality claims shall be presented for defects or deficiencies in quality noticed during warranty period earliest but not later than 14 days after expiry of the guarantee period.

(d) The Seller shall collect the defective or rejected eqpts from the location nominated by the Buyer and deliver the repaired or replaced eqpts at the same location under Seller's arrangement.

(e) The quality claims will be raised solely by the Buyer and without any certification/ countersignature by the Seller's representative stationed in India.

**24. Warranty.** The following Warranty will form part of the contract placed on successful Bidder:-

(a) The Seller warrants that the eqpts supplied under the contract conform to technical specifications prescribed and shall perform according to the said technical specifications.

(b) The Seller warrants for a period of **12 months from the date of installation and commissioning, or ATP is later**, that the eqpts/stores supplied under the contract and each component used in the manufacture thereof shall be free from all types of defects/failures. Onsite comprehensive warranty will be provided.

(c) If within the period of warranty, the eqpts are reported by the Buyer to have failed to perform as per the specifications, the Seller shall either replace or rectify the same free of charge provided that the eqpts are used and maintained by the Buyer as per instructions contained in the Operating Manual. Warranty of the equipment would be extended by such duration of downtime. Record of the down time would be maintained by the user in the logbook. Spares required for warranty repairs shall be provided free of cost by the Seller. The Seller also undertakes to diagnose, test, **20 of 40** adjust, calibrate and repair/replace the eqpts/equipment arising due to accidents by neglect or misuse by the operator or damage due to transportation of the eqpts during the warranty period, at the cost mutually agreed to between the Buyer and the Seller.

(d) The Seller also warrants that necessary service and repair back up during the warranty period of the equipment shall be provided by the Seller and he will ensure that the downtime within 0.5 % of the warranty period. This amounts to total maximum downtime of six days during warranty.

(e) The seller will place a service engineer at the site for the duration of the warranty period. The Seller shall associate technical personnel of the maintenance agency and Quality Assurance Agency of the buyer during warranty and shall also provide the details of complete defects, reasons and remedial actions for defects.

(f) If a particular equipment/eqpts fails frequently and/or, the cumulative down time exceeds 1.5 % of the warranty period, the complete equipment shall be replaced free of cost by the Seller within a stipulated period of 30 days of receipt of the notification from the Buyer. Warranty of the

replaced equipment would start from the date of acceptance after Joint Receipt Inspection by the Buyer/date of installation and commissioning.

Proprietor/Partner of The Firm \_\_\_\_\_

(g) During the warranty period, all warranty benefits received by the seller from the OEMs, for any equipment pertaining to third parties will be passed on in to the Buyer.

(h) Where the tenders are quoted for by resellers/channel partners on behalf of OEMs, proof in writing to the effect that a back to back arrangement/exercising of support pack options exists with the OEM for entire duration of warranty, shall be provided on placement of supply order. Failure to provide sufficient proof for the arrangements shall either result in non-processing of payments due to the vendor or cancellation of supply order.

25. Non Disclosure agreement will be given by the bidder duly stamped. Copy of the same is enclosed herewith.

26. **Bidder Financial Standing-** The bidder should not be under liquidation, court receivership or similar proceedings, should not be bankrupt. Bidder to give undertaking to this effect with bid.

27. Installation, commissioning, testing, configuration, training (if any- which ever is applicable as per scope of supply) is to be carried out by OEM/OEM certified resource or OEM authorized Reseller.

28. **Payment terms** - The payment shall be made based on milestones as follows. Every installment of payment shall be released only after completion of that particular milestone duly approved by nominated Board of Officers.

<u>Ser No</u>	<u>Type of Work</u>	<u>Time to be taken to work completion</u>	<u>Payment schedule(% age of total cost)</u>	<u>Remarks</u>
(a)	Commencement of Work, Construction of civil work & provision of iron items for construction of shed at the site.	05 week	35% of the total cost (on completion only)	This payment will be released after producing 10% security as FDR of total construction cost.
(b)	Fitting of material/ construction of multipurpose shed duly completed in all respect.	Further 05 week	45% of the total cost (on completion only)	
(c)	Fixing of pre-galvalumed sheet on the multipurpose shed duly completed in all respect and final inspection of the construction of the multipurpose shed by the bd of officers.	Further 03 week	20% of the total cost (on completion only)	

29. Bidders shall be deemed to have read, understood and willing to abide by this document when they submit their bids. Accordingly, this form duly signed on each page with office stamp of the firm shall be submitted alongwith the bid documents; failing which the bid shall be considered invalid and no cognizance shall be taken of it.

Dated :

2024

\_\_\_\_\_  
(Sig of Proprietor/Partner of the Firm  
alongwith stamp)

### **INSTRUCTION TO TENDERERS**

1. The tender cost/value includes cost of cement, reinforcement steel, structural steel, lighting system and fans and all other related material required for completion of the work.
2. Time is the essence of the contract. Being a time bound project, the contractor should make all efforts to complete the work in time.
3. **Time Line for completion of Project** -Even though the overall completion period is indicated as **Ninety days**, the work shall be completed progressively and handed over as per agreed split up schedule if any.
4. The tenderers are advised to visit the site and get themselves acquainted with the site conditions before submitting the offer.
5. Quoted rate shall remain valid for a period of 180 days from the date of tender opening for the release of work order and will be firm throughout the contract period of **One Hundred Eighty days** or till completion of work, once awarded and no cost escalation is allowed on any account.
6. The item rate offered is for finished item of works and shall provide for the complete cost towards fuel, tools, tackles, plant & machinery, temporary works, labour, materials, levies, taxes, transport, lay-out, repairs, rectifications, maintenance till handing over, supervision, labour colonies, establishment, services, roads, revenue expenses, overheads, profits & all other incidentals etc., complete. Rate quoted shall include GST.

**The Tenderer should be a GST Registered Contractor and should have filed returns with respect to GST and proof of documents should be furnished (Minimum last 05 GST returned filled to be attached). If the proof of ESI, EPF & GST registration is not furnished the tender of the tenderer will not be eligible for opening price bid and become disqualified.**

7. Some changes are likely in the quantities furnished as well as in the layout, design and specifications of the work. The rates quoted shall be deemed to be inclusive of all such contingencies
8. The work shall be carried out as per drawings released then and there, BIS/as per specifications, and standard code of practice and as per the instructions of Engineer-in-charge. **Tenderer has to quote rates both in figures and in words for all the items given in the Bill of Quantities provided in the Price Bid.**
9. The contractor has to furnish the security deposit, as per the Clause indicated elsewhere in this document, if the work is awarded. Further the contractor has to furnish the



security deposit before signing of agreement and commencement of work.

Proprietor/Partner of The Firm \_\_\_\_\_

10. Since the responsibility for the quality, workmanship and accuracy of any work being carried out under this contract lies with the contractor, the contractor should ensure that no work is done without the presence of contractor's representative at the work spot, whose strength depends on the value of contract awarded. The contract should arrange for surveying construction site at his own cost.
11. The decision of PMG board and Army Public School, Ambala Cantt shall be final and binding on the contractor regarding clarification of items in this tender schedule.
12. The works contract to be entered into with the successful tenderer will be governed as per directions of Army Public School, Ambala Cantt.
13. The contractor shall strictly adhere to various labour laws in force.
14. To safeguard the persons working at height in roof, wall etc., sufficient number of Industrial Safety nets shall be provided at tenderer's cost in appropriate level and locations. The working hand including Supervisors, Engineers should wear the personal protective items and safety measures such as helmets, safety belts, shoes, etc., before entering into working place.
15. The tenderer has to deploy adequate labour of required categories such as Unskilled, Skilled, Mason, Carpenter, Plumber, Welder, Fitter, Mistry, Technically experienced, etc. so as to execute the works simultaneously in all areas of work.
16. Expertise labour only to be engaged for specialized items of work like laying of ceramic tiles, marbles, cuddapah slabs, granite slabs and false ceiling, partition, wall paneling, architectural finishing etc. and work experienced persons shall be engaged for fabrication, water supply, railway track laying and aligning works, sewerage system work, etc.
17. The contractor shall follow norms of Army Public School, Ambala Cantt security system for movement of men & materials within the School complex.
18. All the works shall be executed as per the standard specifications as provided.
19. All the materials to be used in the work and the nature of work shall conform to the respective BIS and National Building Organisation, and shall be got approved by the PMG board and Army Public School, Ambala Cantt before actual incorporation in the work.
20. All materials brought by the Contractor for incorporation in the work shall be got inspected and approved by the PMG board and Army Public School, Ambala Cantt before they are incorporated in the work.
21. All safety measures are to be followed during execution of work, engaged for this purpose. Sufficient care shall be taken by the contractor during excavation to avoid

damages to the buried pipelines, cables and other infrastructure if any etc. Damages caused if any shall be rectified at contractor's risk and cost.

Proprietor/Partner of The Firm \_\_\_\_\_

22. The contractor should extend fullest co-operation with the third party agencies engaged, if any by the School, to adhere the Quality Control Procedures ensuring quality.
23. The contractor should extend full co-operation to the other contractors who may be doing other works in the same areas to enable them to execute their portions of work without any delay or difficulty.
24. Tenderers are requested to furnish the cancelled cheque leaf to accept Electronic fund transfer / R T G S transfer for any payment from Army Public School, Ambala Cantt.
25. Payment will be given as per mutual agreement.
26. Penalty clause is applicable as per APS, Ambala Cantt rules and regulations.
27. Army Public School, Ambala Cantt reserves its right to reject a tender due to unsatisfactory past performance in the execution of a contract awarded against a different Tender.
28. The tenderer has to ensure payment of Minimum Wages as per State rules and Minimum Wages as applicable under law from time to time.
29. The Contractor shall have to remit EPF & ESI contributions at the rates applicable under law to the authorities concerned for the total wages paid / abide by BOCW Act / Coverage in Group Insurance Scheme / All Risk Policy.
30. Rate for each item should be quoted in FIGURES and in WORDS. In case of any difference in the rates quoted in figures and in words, the lower of the two rates will be taken as the tendered rate. Unit rate quoted shall be the basis for arriving the total value of the tender. The total amount for every item shall be arrived by multiplying the unit rate with the quantity indicated for that item. In case of any arithmetic deviation is noticed in the total amount, the same will be corrected and evaluated by taking unit rate as basis and multiplying with the quantity indicated.
31. Tenders received after the due date and time of opening, will not be accepted.
32. The contractor's responsibility under this contract shall commence from the date of receipt of the LOI by the tenderer. The scheduled period of completion for this work is as mentioned in page No. 01, and the Contractor will have to plan his work accordingly.
33. Generally, the maintenance period/Defect Liability period for any work under Army Public School, Ambala Cantt will be 01 Year (One Year) from the date of completion.
34. All the documents shall be duly signed with seal in all pages and placed in a common sealed cover duly superscripting the **Name of Work, Tender reference** and submitted.
35. Tenderer should furnish the RATE in the enclosed tender "Financial Bid" and shall be

duly signed with seal in all pages and placed in a separate sealed cover duly superscripting the cover "FINANCIAL BID".

Proprietor/Partner of The Firm \_\_\_\_\_

36. The Demand Draft towards Document cost & EMD along with complete tender document consisting Technical qualification details but excluding price bid shall be placed in a separate cover duly superscripting the cover "Technical Bid". Tender without EMD or document cost will be rejected.

37. **Two Bid System** - The work will be carried out under Two Bid System:-

(a) The Technical Bids shall be opened as per date mentioned. The evaluation of technical Bid will be carried out by Board of Officers.

(b) The Commercial Bids of only those Bidders whose technical bids meet all the stipulated (Technical) requirements shall be opened.

38. Totally there will be 2 Separate sealed covers. One cover containing Document cost, EMD and the tender documents containing Technical Qualifications and the other containing the "Price Bid" both the contents duly signed with seal in all pages.

39. Both the above 2 Covers shall be placed in a Common Sealed Cover and submitted before the said due date as given above superscripting the tender Date and DueDate.

40. Any deviation to this tender terms & condition and schedules of this tender will cause total rejection of the offer submitted

41. Incomplete offers will become liable for rejection.

42. Tender addressed to **The Principal, Army Public School, 90 Alexendra Road, Ambala Cantt** will be received & opened as per the schedule of tender notice.

43. Tender submitted by post should be sent superscripting "**The Principal, Army Public School, 90 Alexendra Road, Ambala Cantt**". These should be posted with due allowance for any postal delay. Tender received after due date and time of opening tenders, will be rejected and Army Public School, Ambala Cantt will not be responsible for any postal delay.

44. **Earnest Money Deposit:** An EMD of 3% of the total cost i.e Rs 1,50,000/- of the project will be deposited as security in the form of FDR in favour of Principal APS Ambala Cantt as bank Gurantee. After one year of completion of the work in all respect by the PMG, aspects have been checked and are found as satisfactory, the FDR will be returned. Defect Liability period of the subject work will be min one year from the date of completion of the work.

EMD of the successful and unsuccessful contractor shall be refunded immediately after finalization of the contractor. EMD shall not carry any interest.

Proprietor/Partner of The Firm \_\_\_\_\_

#### **45. Performance guarantee**

The successful tenderer, hereafter referred to as the contractor, shall deposit an amount equal to 5% of the tendered and accepted value of the work (without limit) as performance guarantee in the forms of: Banker's Cheque/Demand Draft

The time allowed for submission of the performance guarantee by the contractor shall be decided by the Army Public School, Ambala Cantt approving authority for a period ranging from 4 to 15 days of issue of the letter of acceptance, depending upon the magnitude and/or urgency of the work. A sample copy of the letter of acceptance to the contractor for submission of the performance guarantee is given in Annexure-I.

46. **Security Deposit** - The security deposit shall be refunded to the contractor after successful completion of maintenance period/Defect liability period of one year. The refund of security deposit and performance guarantee will not carry any interest.
47. If the tenderer deliberately gives wrong information in his tender or creates conditions favorable for the acceptance of his tender, Army Public School, Ambala Cantt reserves the right to reject such tender at any stage.
48. The expenses for completing and stamping the agreement shall be paid by the contractor.
49. Tenderers shall not increase their quoted rate in case Army Public School, Ambala Cantt negotiates for reduction of rate. Such negotiation shall not amount to cancellation or withdrawal of the original offer and the rate originally quoted shall be binding on the tenderers for a period of six months from the date of opening of tenders.
50. Canvassing in any form in connection with tenders is strictly prohibited and the tenders submitted by the contractors who resort to canvassing will be liable to rejection
51. All entries in the tender documents should be in one ink. Erasers and over writings are not permitted. All cancellations and insertions should be duly attested by the tenderer concerned.
52. TENDERERS should fill in all the required particulars in the blank spaces provided for this purpose in the tender documents and also sign each and every page of Tender Documents including the drawings attached there to, before submitting their tender.
53. Conditional and Unwitnessed tenders, tender containing absurd rates and amounts tenders which are incomplete or otherwise considered defective and tenders not in accordance with the tender conditions laid down by the Accepting Officer are liable to be rejected.
54. Tenders not submitted on the prescribed form are liable to be rejected.
55. This tender notice shall be deemed to form an integral part of the contract to be entered

into for this work.

Proprietor/Partner of The Firm \_\_\_\_\_

56. The tenderers are advised to go through the condition stipulated in Tender document & code of conduct for Safety of Contract Labourer in details. Any violation thereof will invite punitive action being taken against them. While quoting the rate all the above factors are to be taken into account.
57. Agency registered with NSIC is exempted from payment of tender document cost & Earnest Money Deposit but to submit security deposit. They are required to attach the attested copy of registration indicating the company name, address, registration number, validity & product for which registered in the technical bid,. Any deviation in the certificate on product or validity or name of the company tendering, will attract rejection resulting non-opening of respective price bid.

**58. Compensation for Delay:**

If the contractor fails to maintain the required progress or to complete the work and clear the site on or before the contracted or extended period of completion, he shall, without prejudice to any other right or remedy of the Army Public School, Ambala Cantt on account of such breach, pay as agreed compensation an amount calculated as stipulated below or such smaller amount as may be fixed by the Army Public School, Ambala Cantt on the contract value of the work for every week that the progress remains below or that the work remains incomplete. This will also apply to items or group of items for which separate period of completion has been specified.

For this purpose the term 'Contract Value' shall be the value at contract rates of the work as ordered and the compensation for delay is by way of recovery at 1 percent of contract value per week of delay provided always that the total amount of compensation for delay to be paid under this condition shall not exceed 10% of the contract value or of the contract value of the item or group of items of work for which a separate period of completion is given.

The amount of compensation may be adjusted or set-off against any sum payable to the Contractor under this or any other contract with the Army Public School, Ambala Cantt.

**59. Arbitration:**

Except where otherwise provided for in the contract all questions and disputes relating to the meaning of the specifications, designs, drawings and instructions hereinbefore mentioned and as to the quality of workmanship or materials used on the work or as to any other question, claim, right, matter or thing whatsoever in any way arising out of or relating to the contract, designs, drawings, specifications, estimates, instructions, orders or these conditions or otherwise concerning the work or failure to execute the same whether arising during the progress of the work or after the completion or abandonment thereof shall be referred to the sole arbitration of the Chairman of Army Public School, Ambala Cantt and if Chairman is unable or unwilling to act, to the sole arbitration of some other person appointed by the Chairman, willing to act as such arbitrator. The cases referred to arbitration shall be other than those for which the decision of the Engineer-in-charge is expressed in the contract to be final and conclusive. There will be no objection if the arbitrator so appointed is an employee of Army Public School, Ambala Cantt and that he had to deal with the matters to which the contract relates and

that in the course of his duties as such he had expressed views on all or any of the matters in dispute or difference.

Proprietor/Partner of The Firm \_\_\_\_\_

The arbitrator to whom the matter is originally referred being transferred or vacating his office or being unable to act for any reason, Chairman as aforesaid at the time of such transfer, vacation of office or inability to act, shall appoint another person to act as arbitrator in accordance with the terms of the contract. Such person shall be entitled to proceed with the reference from the stage at which it was left by his predecessor. Subject as aforesaid the provision of the Arbitration & Reconciliation Act, 1996 or any statutory modification or re-enactment thereof and the rules made there under and for the time being in force shall apply to the arbitration proceeding under this clause.

It is a term of the contract that the party involving arbitration shall specify the dispute or disputes to be referred to arbitration under this clause together with the amount or amounts claimed in respect of each such dispute. The arbitrator(s) may from time to time with consent of the parties enlarge the time for making and publishing the award.

The work under the Contract shall, if reasonably possible, continue, during the arbitration proceedings and no payment due or payable, to the Contractor shall be withheld on account of such proceeding.

The Arbitrator shall be deemed to have entered on the reference on the date he issues notice to both the Parties fixing the date of first hearings. The arbitrator shall give a separate award in respect of each dispute or difference referred to him. The venue of arbitration shall be such place as may be fixed by the Arbitrator in his sole discretion.

The award of the arbitrator shall be final, conclusive and binding on all parties to this contract.

In the event of disputes or differences arising between one public sector enterprise and a Govt. Department or between two public sector enterprises the above stipulations shall not apply or its amendments for arbitration shall be applicable.

#### **59. Force Majeure clause:**

If at any time during the continuance of this contract the performance in whole or in part by either party of any obligations under this contract shall be prevented or delayed by reason, of any war, hostilities, acts of the public enemy, civil commotion, sabotage, fires, explosions, epidemics, quarantine, restrictions or acts of GOD (hereinafter referred to as events) then provided notice of happening of any such events is given by either party to other within twenty one days from the date of occurrence thereof neither party shall reason of such events be entitled to terminate this contract nor shall either party have any such non-performance and delay is resumed as soon as practicable after such events has come to an end or ceased to exist. If the performance in whole or part of any obligation under this contract is prevented or delayed by reason or any such event claims for extension of time shall be granted for period considered reasonable by Army Public School, Ambala Cantt subject to prompt notification by the tenderer to Army Public School, Ambala Cantt of the particulars of the events and supply to the Army Public School, Ambala Cantt if required of any supporting evidence. Any waiver of time in respect of partial installment shall not be deemed to be a waiver of time in respect of remaining deliveries.

Proprietor/Partner of The Firm \_\_\_\_\_

The correspondence exchanged against the tender from both tenderer and Army Public School, Ambala Cantt through email are considered as valid document legally though it is not signed. It is treated as valid confirmations made on behalf of the respective company and very much comes under the legal ambit of the business transaction and hence it is binding on both the parties to the business.

Any transaction pertaining to the tender from both the parties of business done round the clock irrespective of the office or business hours of the companies, are valid legally and binding on both the parties. This applies to the extent only in such cases where deadline time for transaction is not specifically declared by either or both the parties to the business.

In case Letter of Intent (LOI) is issued through email, the PC generated time and date of mail shall be construed as the official time and date of release of LOI. In as much as this date is within the last date of validity given by the tenderer the LOI is said to have been issued within the validity period and shall be binding on both the parties to the business.

Tenderers participating in the tender should declare in their technical bid that whether they have been black-listed / kept on hold for a specified period / given Business holiday for a specified period by any Public sector undertaking or Government departments. The reasons for such action with details and the current status of such hold shall be clearly furnished to Army Public School, Ambala Cantt. If no such details are mentioned in the offer then it will be construed that the subject tenderer is not under any such hold. But at a later date if it comes to the notice of Army Public School, Ambala Cantt about any such hold under enforcement on the subject tenderer, Army Public School, Ambala Cantt will have every right to reject the offer of such vendors at any point of time and also under any stage of the finalisation of the subject tender irrespective of the status of the subject tenderer in that tender. Such tenderers will not be permitted to participate in the further tender proceedings and will be communicated suitably. They will not be also considered for any ongoing tenders even if participated till the hold is officially lifted and confirmed in writing.

Dated :

2024

\_\_\_\_\_  
(Sig of Proprietor/Partner of the Firm  
alongwith stamp)

## **GENERAL CONDITIONS OF CONTRACT**

1. No night work will be permitted without the written permission of the Army Public School, Ambala Cantt.
2. Permission for erection of temporary work sheds etc., at site will have to be obtained from Army Public School, Ambala Cantt in writing in advance.
3. The works contract to be entered into with the successful tenderer will be governed as per the directions of the Army Public School, Ambala Cantt
4. The successful tenderer / Contractor shall observe all safety regulations and take necessary safety precaution as called for and Safety Precautions enclosed herewith.
5. In all matters of dispute, the decision of the chairman, Army Public School, Ambala Cantt Shall be final and binding on the tenderer / contractor.
6. Some changes are likely in the quantities furnished as well as in the layout, design and specifications of the work. The rate quoted shall be deemed to be inclusive of all such contingencies.
7. All the materials to be used in the work and nature of work shall conform to respective BIS and National Buildings Organisation Standard Specifications and shall be got approved by the Army Public School, Ambala Cantt through PMG before actual incorporation in the work.
8. All materials brought by the Contractor for incorporation in the work shall be got inspected and approved by the Army Public School, Ambala Cantt through PMG before they are incorporated in the work
9. Engineer in charge / Civil or PMG representative shall have all reasonable times access to Contractor's premises of work and shall have the power at all the reasonable times to inspect and test any portion of the work or examine the materials and workmanship of the structures during their manufacture and test. The contractor shall give due notice in writing to the PMG committee and Army Public School, Ambala Cantt when the materials supplied to be incorporated in the work are ready for Inspection and test. No material shall be incorporated in the work until PMG committee certified in writing that such materials have been inspected and approved by him or else the rejected material should be removed from site immediately.
10. The Contractor shall closely scrutinize all the drawings issued in connection with the work by this organization and bring to the notice of the PMG if any discrepancies, omissions in the drawings before undertaking the actual work pertaining thereto.
11. **Progress of work** - The contractor should submit in advance every fortnight a detailed programme of work to be undertaken from time to time strictly in conformities with the "Time and Progress Chart" covering the entire constructed work and reschedule them wherever necessary during the progress of the work so as to achieve the target set.

Proprietor/Partner of The Firm \_\_\_\_\_



12. The contractor should extend full co-operation to the other contractors who may be doing other works in the same areas to enable them to execute their portions of work without any delay or difficulty.

### **GENERAL SAFETY PRECAUTIONS TO BE FOLLOWED AT WORK SITE DURING EXECUTION**

**The following safety measures should be strictly adhered to, during execution of works at sites.**

1. Providing the working platform with toe board and handrail for continuous working at heights.
2. Providing safety belt and life line at all times for men working at heights.
3. Providing dust or fume respirator in places where dust and fume concentration exists.
4. Providing goggles and welding screens.
5. Providing acid and alkali proof rubber gloves for handling acid and alkali and Chemical which are corrosive.
6. Providing rubber gloves for working on electrical works.
7. Ensuring proper lashing of the components while being transported in vehicles.
8. The vehicles must have side supports or have body to support the materials Conveyed.
9. The materials should not be allowed to extend or overflow the sides of the vehicles.
10. Materials should not be allowed to overhang from the rear edge of the body of the Vehicle.
11. Driver of the vehicle must possess license.
12. Vehicle must not be overloaded prescribed limits.
13. Red flags and lights for parts projecting from the body of vehicle must be provided.
14. The speed restrictions within the Institute must be strictly adhered to.
15. The gas cylinders must be always handled on trolleys or kept tied down not in use. They should never be rolled as Roller for conveying.
16. Cylinders should not be used without regulators.

Proprietor/Partner of The Firm \_\_\_\_\_

17. All excavations must be barricaded and red lamps must be provided.
18. All electrical connections must be properly earthed.
19. Providing helmet, safety belt, etc., for high level work and sufficient number of Industrial Safety nets at appropriate level to safeguard the persons working at high level particularly in roofing etc.,
20. All personal protective equipment conform with standard specification and Contractor including their sub-contractors, agents and labour engaged on the work are required to scrupulously adhere to the safety regulations, safety precautions and measures. Any violation thereof will invite punitive action being taken against them. Also contractors with frequent violations of safety regulations will not be entrusted with further work in this organization.

## **SAFETY PRECAUTIONS TO BE OBSERVED WHILE TRANSPORTING MATERIALS**

### **I. VEHICLE**

Vehicles carrying material should have proper registration documents and must be produced on demand by our Security Staff.

The light on right side, i.e., over the driver's cabin shall be in working condition.

Both the head lights as well as park lamps must be in working conditions.

### **II. MOVEMENT OF VEHICLE**

1. The vehicle should not travel at more than 20 km.ph in our premises.
2. The Driver of the vehicle must possess heavy duty license and produce on demand by the Security Staff.
3. Vehicles carrying inflammable liquids in the tank containers should have grounding Chain or the tank should be coated with insulating material also to avoid Static Electricity.
4. In road junctions, speed breakers and railway crossing, the speed should be lowered and vehicle should proceed cautiously.
5. The driving should 'KEEP TO THE LEFT' at all places.
6. The vehicle should not be parked in road which could obstruct the vehicular traffic.
7. No person other than driver should be allowed to sit or stand on the prime mover or trailer.

Proprietor/Partner of The Firm \_\_\_\_\_

8. The vehicle should pass only through the approved routes. Short cuts should be forbidden.
9. There must be a safe distance behind another moving truck.
10. The driver should avoid making quick starts, jerky stops or quick turns at excessive speed.

**TERMS AND CONDITIONS REGARDING COMPLIANCE WITH VARIOUS LABOUR LAWS BY THE CONTRACTORS FOR ARMY PUBLIC SCHOOL, AMBALA CANTT**

1. The Contractor shall not employ in connection with the work any person who has not completed 18 years of age.
2. The Contractor shall in respect of labour employed by him either directly or through Subcontractors comply with or cause to be complied with the following statutory provisions and rules and in regard to all matters provided therein.
  - a) The Contract Labour (Regulation & Abolition) Act 1970
  - b) The Minimum Wages Act 1948 and related Central Rules.
  - c) The Payment of Wages Act 1936 and related Central Rules.
  - d) The Employee's Provident Fund & Miscellaneous Provisions Act 1952.
  - e) The Employees State Insurance Act 1948.
  - f) The Workmen Compensation Act 1923.
  - g) The Industrial Disputes Act 1947.
  - h) The payment of bonus act 1965

And any other law or modifications to the above or to the Rules made hereunder from time to time.

3. The Contractor employing 20 or more workmen is required to obtain license from the authorities (The Deputy Chief Inspector of Factories / Assistant Commissioner of Labour as the case may be). The license shall be amended and / or renewed Wherever, there is an increase in the workmen employed by him or in the event of Contract being extended or renewed. The Contractor shall inform the license number to the Army Public School, Ambala Cantt before taking up the work.
4. The Contractor (Licensed or unlicensed) shall promptly furnish every information and document required by Army Public School, Ambala Cantt authorities for the purpose of fulfilling their Obligations as Principal Employer and shall render all necessary assistance for thesame.

**WAGES**

5. The Contractor shall pay wages to the workmen employed by him at the rate which shall not be less than the minimum wages applicable under Law from time to time.
6. The Contractor shall fix wage periods in respect of which wages shall be payable. No wage period shall exceed one month.

Proprietor/Partner of The Firm \_\_\_\_\_

7. The Contractor shall ensure payment of wages to the contract labour employed by him within three days from the end of wage period in case the wage period is one week or a fortnight and in all other cases before 7<sup>th</sup> day of the following month.
8. All Payment of wages shall be made on working days at the work site and during the working time and on date notified in advance. In case the work is completed before the expiry of the wage period final payment shall be made within 48 hours of the last working day.
9. Where the employment of any worker is terminated by or on behalf of the Contractor, the wages earned by him shall be paid before the expiry of the second working day from the day on which his employment is terminated.
10. Wages due to every worker shall be paid to him direct or to the person authorized by him in this behalf. All wages shall be paid in current coin or currency in both.

#### **POST TECHNICAL AUDIT OF WORK AND BILLS:-**

11. Army Public School, Ambala Cantt reserves the right to carry out the post-payment Audit and technical examination of the work and final bill including all supporting vouchers, abstractsetc., and enforce recovery of any sum becoming due as a result thereof in the manner provided in the presiding sub-paragraphs. Such recovery shall be enforced any time even after passing the final bill.

#### **SUBMISSION OF BILLS BY CONTRACTOR: -**

12. The Contractor at the end of each stage of work will submit the bill for payment along with the photographs.

#### **PAYMENT OF BILLS:-**

13. All payments to be made to the Contractor, under this contract shall be by NEFT or RTGS within a reasonable time, after the certification of bills by the execution department.

#### **RECOVERY FROM CONTRACTOR:-**

14. Whenever under the contract, any sum of money, shall be recoverable from or payable by the Contractors, the same may be deducted from or any sum then due or which at any time thereafter may become due to Contractor under the contract or under any other contract with Army Public School, Ambala Cantt or from his Security Deposit or he shall pay the claim on demand.

Proprietor/Partner of The Firm \_\_\_\_\_

**CANCELLATION OF CONTRACT FOR CORRUPT ACTS:-**

15. Army Public School, Ambala Cantt, whose decision shall be final and conclusive, shall without prejudice to any other right or remedy which shall have accrued shall accrue thereafter to Army Public School, Ambala Cantt cancel the contract in any of the following cases and the Contractor shall be liable to make payment to Army Public School, Ambala Cantt for any loss or damage resulting from any such cancellation to the same extent as provided in the case of cancellation for default,

**If the Contractor shall:-**

a) Offer or give or agree to give to any person in Army Public School, Ambala Cantt service any gift or consideration of any kind, as an inducement or reward for doing or for bearing to door for having done or for borne to do any act, in relation to the obtaining or execution of this or any other contract for Army Public School, Ambala Cantt service,

**OR**

b) Enter in to a contract with Army Public School, Ambala Cantt in connection with which commission has been paid or agreed to be paid by him or with his knowledge, unless the particulars of any such commission and the terms of payment thereof have previously been disclosed in writing to Army Public School, Ambala Cantt.

**OR**

c) Obtain a contract with Army Public School, Ambala Cantt as a result of ring tendering or by non-bonafide methods of competitive tendering, without first disclosing the fact in writing to Army Public School, Ambala Cantt.

**CANCELLATION OF CONTRACT FOR INSOLVENCY ASSIGNMENT OF TRANSFER OR SUB-LETTING OF CONTRACT:-**

16. Army Public School, Ambala Cantt, without prejudice to any other right or remedy which shall have accrued or Shall accrue thereafter to Army Public School, Ambala Cantt shall cancel the contract in any of the following cases:

**If the Contractor,**

(a) Being an individual or if a firm any partner thereof shall at any time be adjudged bankrupt or have a receiving order for administration of his estate, made against him or shall take any proceedings for liquidation or composition under any bankruptcy Act or assignment of his effects of composition or arrangement for the benefit of his creditors or purport to do so, or if any application made under any

Bankruptcy Act for the time being in force for the sequestration of his estate or if a trust deed be granted by him on behalf of his creditors

**OR**

(b) Being a Company, shall pass a resolution or the Court shall make an order for the liquidation of its affairs, or a receiver or Manager on-behalf of the debenture holders shall be appointed or circumstances shall arise which entitle the Court or debenture holders to appoint a receiver or Manager,

Proprietor/Partner of The Firm \_\_\_\_\_

OR

- (c) Assigns, Transfers, Sub-lets or attempts to assign, transfer or sub-let any portion of the work without the prior written approval of the Army Public School, Ambala Cantt.
- (d) Army Public School, Ambala Cantt exercise the authority to cancel the contract under this conditions, Army Public School, Ambala Cantt may have the work done by any means at the Contractor's risks and expenses provided always that in the event of the cost of the work so done (ascertified by Engineer in charge which is final and conclusive) being less than the contract cost, the advantage shall accrue to the Army Public School, Ambala Cantt and if the cost exceeds the money due to Contractor under the contract, the Contractor shall either pay the excess amount ordered by Army Public School, Ambala Cantt. or the same shall be recovered from the Contractor by other means.
- (e) In case the Army Public School, Ambala Cantt carries-out the work under the provisions of this condition the cost to be taken into account in determining the excess cost to be charged to the Contractor under this condition shall consist of the cost of the materials, hire charges of tools and plants and/or labour provided by the Army Public School, Ambala Cantt with an addition of such percentage to cover superintendence and establishment charges as may be decided by Estate Maintenance Dept., whose decision shall be final and conclusive.

**CANCELLATION OF CONTRACT IN PART OF FULL FOR CONTRACTOR'S DEFAULT:**

**17. If the Contractor:**

- (a) makes default in carrying out the work as directed and continues in that state after a reasonable notice from Engineer in charge or his authorised representative
- (b) fails to comply with any of the Terms and Conditions of the contract or after reasonable notice in writing with orders properly issued there under.
- (c) Army Public School, Ambala Cantt may without prejudice to any other right or remedy which shall have accrued or shall accrue thereafter to Army Public School, Ambala Cantt, CANCEL the contract as whole or in part thereof or only such work order or items of work in default from the contract. Whenever Army Public School, Ambala Cantt exercise the authority to cancel the contract as whole or part under this condition Army Public School, Ambala Cantt may complete the work at the contractor's risk and cost (as certified by Army Public School, Ambala Cantt, which is final and conclusive) being less than the contract cost, the advantage shall accrue to the Army Public School, Ambala Cantt. If the cost exceeds the money due to the Contractor under this contract the Contractor shall either pay the excess amount ordered by Estate Maintenance Dept. or the same shall be recovered from the Contractor by other means. In case the Army Public School, Ambala Cantt carries out the work or any part thereof under the provisions of the conditions the cost to be taken into account in determining the excess cost to be charged to the Contractor under this condition shall consist of the cost of the materials, hire charges of tools and plant and/or labour provided by the Army Public School, Ambala Cantt with an addition of such percentage to cover the superintendence and establishment charges as may be decided by the Army Public School, Ambala Cantt, whose decision shall be final and conclusive.

Proprietor/Partner of The Firm \_\_\_\_\_

**TERMINATION OF CONTRACT ON DEATH OF CONTRACTOR. :-**

18. Without prejudice to any of the rights or remedies under this contract, if the Contractor dies, or if the firm is dissolved or the company is liquidated, Army Public School, Ambala Cantt Y shall have the option of terminating the contract without compensation to the Contractor.

**SPECIAL POWER TO TERMINATION:-**

19. If at any time after the award of contract, Army Public School, Ambala Cantt shall for any reason whatsoever not require whole or any part of the work to be carried out the Engineer in charge shall give notice in writing of the fact to the Contractor who shall have no claim to any payment of compensation or otherwise howsoever on account of any profit or advantage which he might have derived from the execution of the work in full but which he did not derive in consequence of the fore-closing of the work.

**LABOUR:-**

20. The Contractor shall remain liable for the payment of all wages or other moneys to his work-people or employees under the payment of Wages Act 1936, Employees Liability Act. 1938, Workmen's Compensation Act 1923 or any other Act or enactment, relating thereto and rules framed, thereunder from time to time.

**PRECAUTIONS AGAINST RISK:-**

21. The Contractor shall be responsible for providing at his own expense for all precautions to prevent loss or damage from any and all risks and to minimize the amount of any such loss or damage and for the necessary steps to be taken for the said purpose.

**22. Corrigendum / Amendment:**

It is tenderer's responsibility to watch for any corrigendum or amendment till the opening of a particular tender that will be posted only at School web site.

Dated : 2024

\_\_\_\_\_  
(Sig of Proprietor/Partner of the Firm  
alongwith stamp)

**CERTIFICATE OF ACCEPTANCE OF TERMS AND CONDITIONS**

“We, \_\_\_\_\_ Pvt Ltd, \_\_\_\_\_ unconditionally accept the terms and conditions of the bid published by APS, Ambala Cantt for construction of multipurpose Shed over assembly ground at APS Junior Wing, Ambala Cantt as a framed structure as per specification, dimensions given, STAAD drawing and details specified and directed.”.

Dated : 2024 \_\_\_\_\_  
(Sig of Proprietor/Partner of the Firm alongwith stamp)

**CERTIFICATE OF NON DISCLOSURE AGREEMENT**

1. “We, \_\_\_\_\_ Pvt Ltd, \_\_\_\_\_ hereby declare that we will not disclose the contract or any provision or part of whole of the project details, specification, plan, design, pattern, sample or information thereof to any third party during and after expiry of contract in r/o “Construction of multipurpose Shed over assembly ground at APS Junior Wing, Ambala Cantt as a framed structure as per specification, dimensions given, STAAD drawing and details specified and directed, to anyone without written consent of the APS Ambala Cantt”.

2. If defying the norms as per the contract a legal action may be taken against you/firm as per the existing rules.

Dated : 2024 \_\_\_\_\_  
(Sig of Proprietor/Partner of the Firm)



**CERTIFICATE FOR TENDER DOCUMENT**

To

The Principal,  
Army Public School  
School-133001.

I / We hereby offer to carry out the work of construction of multipurpose Shed over assembly ground at APS Junior Wing, Ambala Cantt as a framed structure as per specification, dimensions given, STAAD drawing and details specified and directed.”

I / We hereby carefully perused the following documents connected with the above noted work and agree to abide by the same.

1. Specifications (Form-I)
2. Drawings
3. Form-II,

I / We forward herewith the sum of Rs..... as Earnest Money, which shall be refunded should this tender be rejected. I / We further agree to deposit such sum which along with the sum of Rs 1,50,000/- mentioned above shall make up 3% of the fully Security Deposit for this work as provided for under conditions of the Army Public School, Ambala Cantt General Conditions of Contract.

I / We further agree to execute all the work referred to in the said documents upon the terms & conditions contained or referred therein, drawings and as detailed in Form-II.

I / We further agree to refer all disputes, as required to the sole arbitration of an Officer, to be appointed by the Chairman, Army Public School, Ambala Cantt., in his sole discretion whose decision shall be final and binding.

**WITNESS**  
Contractor

Signature of the  
  
with stamp affixed

**Date:**

1. ....

2. ....

**CONTRACTOR**

OEM CERTIFICATE

We M/s \_\_\_\_\_ (OEM) is hereby authorise M/s \_\_\_\_\_ (Vendor) to bid in **CONSTRUCTION OF MULTIPURPOSE SHED OVER ASSEMBLY GROUND AT MAIN WING, ARMY PUBLIC SCHOOL, AMBALA CANTT**. We certify that an agreement between M/s \_\_\_\_\_ (OEM) and M/s (Vendor) is in place (Copy enclosed. We M/s \_\_\_\_\_ (OEM) hereby state that we will provide maintenance and repair cover for the project “**CONSTRUCTION OF MULTIPURPOSE SHED OVER ASSEMBLY GROUND AT MAIN WING, ARMY PUBLIC SCHOOL, AMBALA CANTT AS A FRAMED STRUCTURE AS PER SPECIFICATION, DIMENSIONS AND STAAD DESIGN & DRAWING GIVEN AS PER DETAILS SPECIFIED AND DIRECTED**” for a warranty period.

**Company Seal**

(Authorised Signatory of Company)  
With stamp

Place

COMMERCIAL/FINANCIAL BID

PRICE SCHEDULE : CONSTRUCTION OF MULTIPURPOSE SHED  
AT MAIN WING, ARMY PUBLIC SCHOOL, AMBALA CANTT

1. Rates are as under:-

Ser No	Item Description	Units	Basic Rates in figures	GST % & amount	Total amount with Taxes	Total amount in words
	Construction of the multipurpose shed duly completed in all respect at Main wing of Army Public School, Ambala Cantt as per specifications and STAAD design & drawing given. Quality : A1 quality as per sample approved by School.  Dimension- 180'-5" Ft x 120'-5" Ft	One				

2. The rates quoted by the contractor shall include all applicable taxes, octroi, transportation, loading/unloading and labour charges. No additional payment other than what has been quoted for in the tender shall be payable to the contractor under any circumstances.

3. The rates quoted shall be valid for a period of 180 days from the date of opening of the financial bid.

4. Accepting officer reserves the right to resort to re-tender incase the rates quoted are found to be unreasonable.

5. Last date of receipt of sealed tenders duly completed is 1400 hrs on \_\_\_\_\_ 2024. All bids received after \_\_\_\_\_ 2024 (1400 Hrs) shall be considered invalid and shall not be opened.

Station : Ambala Cantt

Dated : 2024

\_\_\_\_\_  
(Sig of Proprietor/Partner of the Firm  
alongwith stamp)



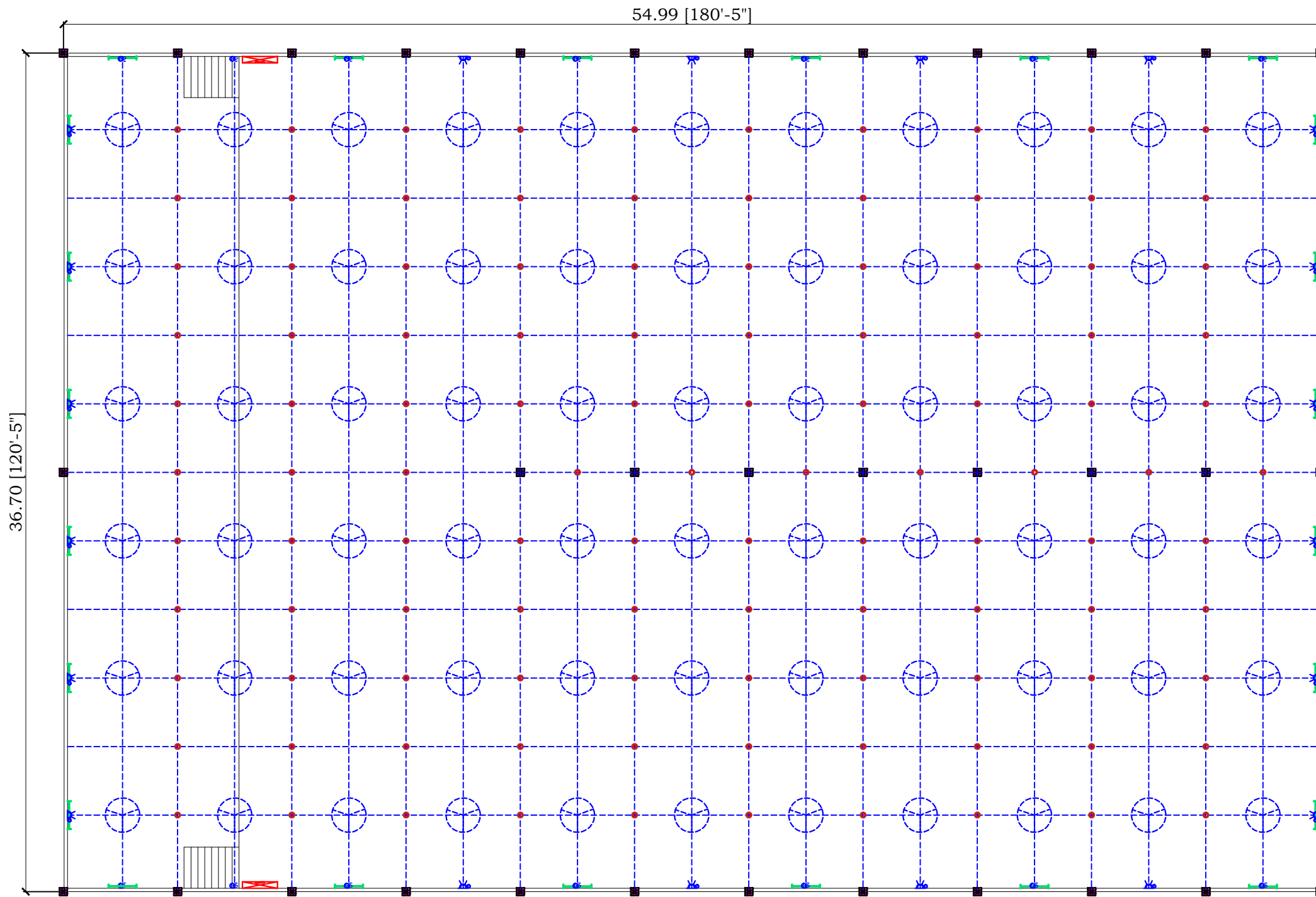

54.99 [180'-5"]

36.70 [120'-5"]

## ELECTRICAL PLAN OF MULTIPURPOSE SHED

LEGEND		
DESCRIPTION	SYMBOL	QTY.
MULTI POWER SOCKET 6X16A OUTLET		20
SWITCH BOARD WITH 5 AMP SOCKET		14
1X4' BATTON LED LUMINAIRE(1X18W)		24
CEILING FAN 1400MM		66
HIGH BEAM DOWN LIGHTER 100 W		110
8 WAY HORIZONTAL DB		02

ENGINEER :

PROJECT :

**MULTIPURPOSE SHED (180x120)**  
AT ARMY PUBLIC SCHOOL,  
AMBALA CANTT.(HR)

TITLE : ELECTRICAL PLAN

DESIGN BY : VIVEK  
CHECKED BY : AKASH

DRAWING NO. : EL-01  
REVISION : R0

DATE : 15.11.2024  
SCALE : N.T.S.

**BUILTECH ENGINEERING SERVICES**  
Deals In : Structural Design, DPR, Analysis & Audit

Office - # 3, Jattan Wali Gali, Ambala City (Haryana)  
+918950117448, +918221828619  
bUILTECHENGGSERVICES@gmail.com

WE BUILD TOMORROW

original copy

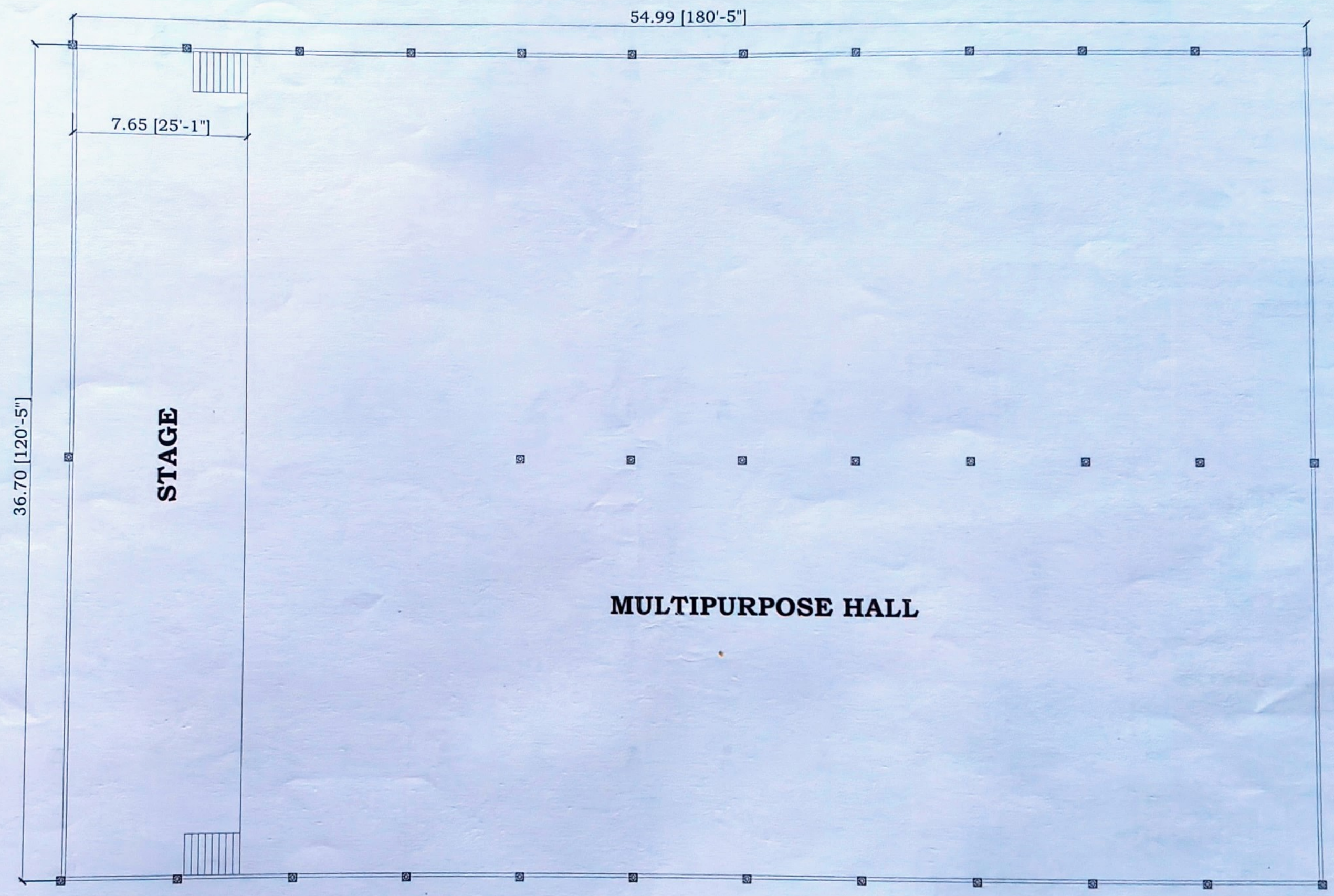

**PLAN OF MULTIPURPOSE SHED**

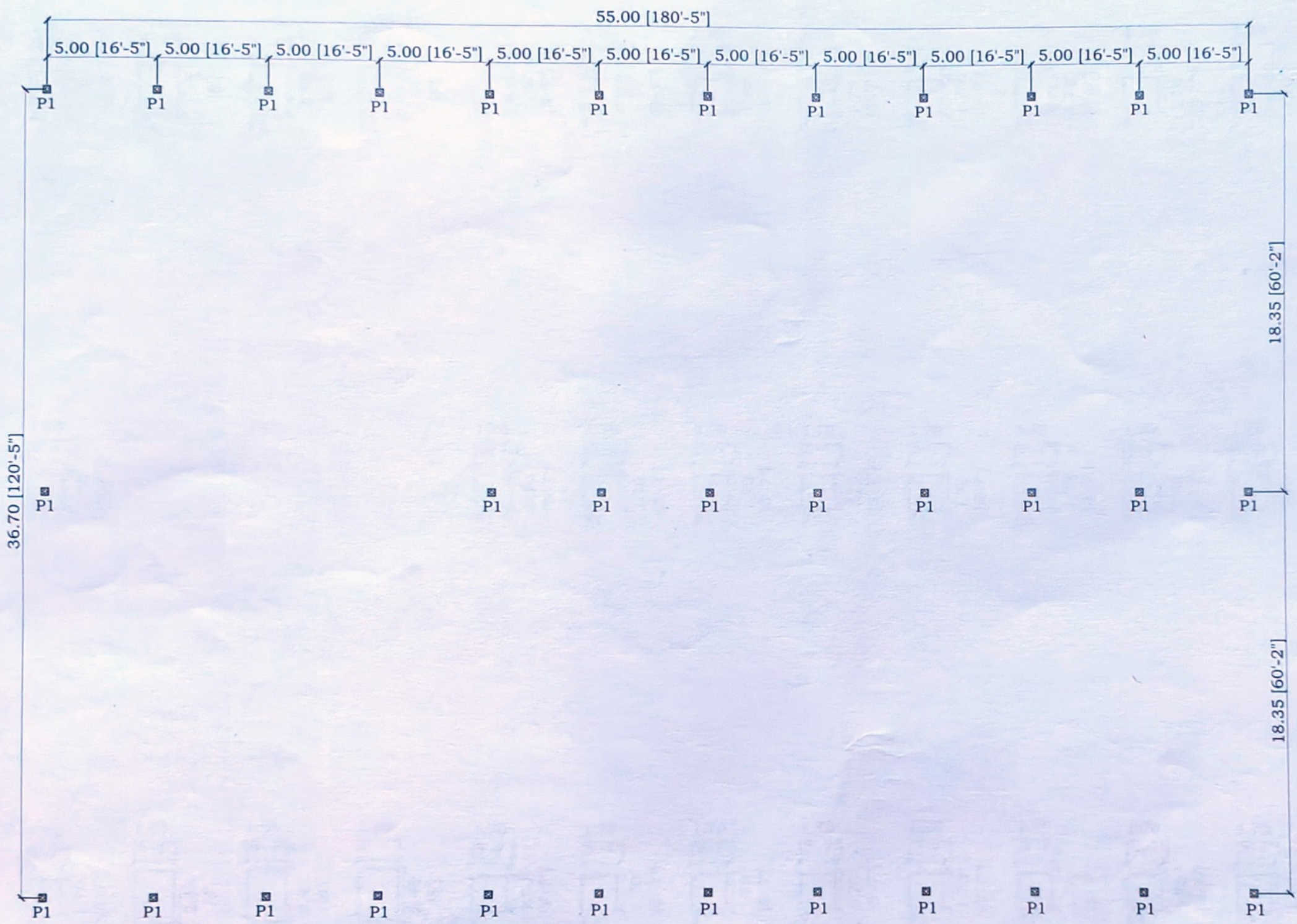

- NOTES:-**
1. DIMENSIONS ARE TO BE READ AND NOT TO BE SCALED.
  2. FOR FOUNDATION DESIGNS , NET ALLOWABLE BEARING CAPACITY OF SOIL HAS BEEN TAKEN AS 10.0 T/M<sup>2</sup> AT 1.50 M DEPTH OF FOUNDATION W.R.T. E.G.L. IN CASE OF VARIATION AT SITE REFER THE MATTER TO DESIGN ENGINEER.
  3. THE FOUNDATION SHALL REST ON FIRM SOIL. IN CASE ANY LOOSE POCKET IS ENCOUNTERED THE STRUCTURAL ENGINEER SHALL BE CONSULTED. EXCAVATED SURFACE, HOWEVER SHALL BE WATERED AND COMPACTED PRIOR TO LAYING OF CONCRETE
  4. CEMENT CONCRETE : M-20 GRADE HAVING CUBE CRUSHING STRENGTH OF 230 KG /CM<sup>2</sup> AFTER 28 DAYS OF CURING.
  5. REINFORCEMENT : TMT BARS OF GRADE Fe 500 D HAVING YIELD STRENGTH OF 5000 KG/ CM<sup>2</sup> AND CONFORMING TO IS 1786-1985 (WITH LATEST AMENDMENT)
  6. CLEAR COVER OF CONCRETE TO REINFORCING BARS  
SLAB = 20MM, BEAMS = 25MM , COLUMNS/ WALLS = 40 MM , FOOTING = 50MM
  7. LAPS IN REINFORCING BARS =48 X DIA OF BARS.  
LAPS TO BE STAGGERED & AVOIDED NEAR MID SPAN.
  8. FOR CHANGE OF DIA OF BAR(S): PROVIDE EQUIVALENT AREA IN CASE OF BARS OF SMALLER DIA AND EQUIVALENT PERIMETER CASE OF BARS OF HIGHER DIA.
  9. LEAN CONCRETE 1:4:8 SHALL PROJECT BEYOND R.C.C. BY 3" .

ENGINEER :

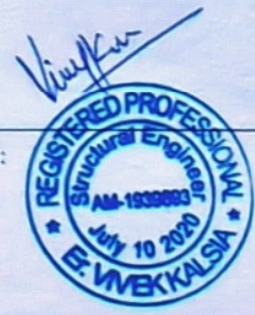

PROJECT :  
**MULTIPURPOSE SHED (180x120)**  
AT ARMY PUBLIC SCHOOL,  
AMBALA CANTT.(HR)

TITLE :  
COLUMN LAYOUT PLAN

DESIGN BY : VIVEK	CHECKED BY : AKASH
DRAWING NO. : STR-01	REVISION : R0
DATE : 06.10.2024	SCALE : N.T.S.

**COLUMN LAYOUT PLAN**

*Kuldeep*  
Prof. Kuldeep Soini  
Assistant Professor  
(Structural Engg.)  
Civil Engineering Department  
PEC, Chandigarh  
Ph. : 78373-52691

**BUILTECH ENGINEERING SERVICES**  
Deals In : Structural Design, DPR, Analysis & Audit

Office - # 3, Jattan Wali Gali, Ambala City (Haryana)  
+918950117448, +918221828619  
bultechenggservices@gmail.com

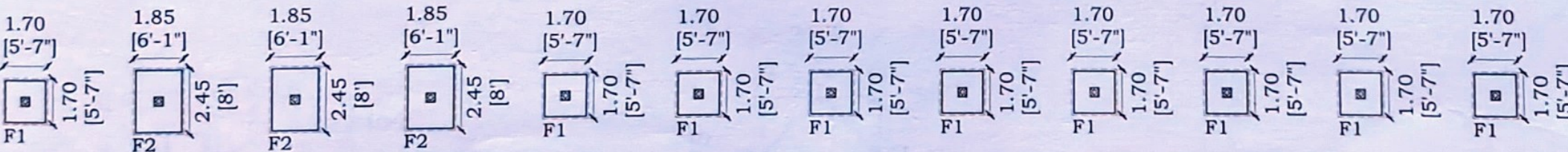
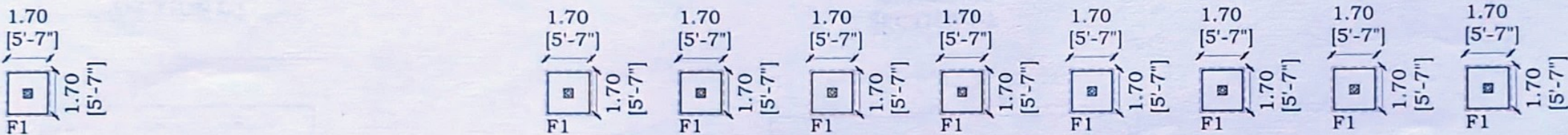
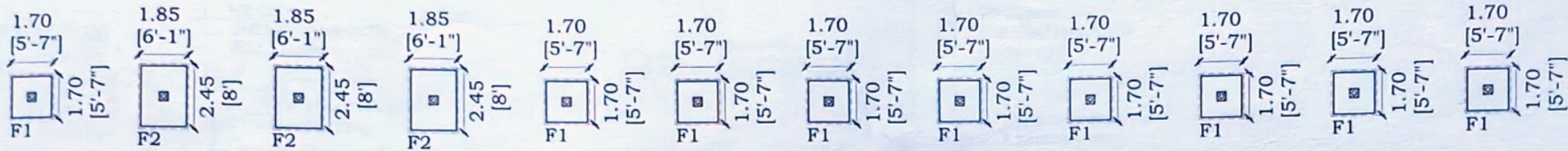

# FOUNDATION PLAN

*Kuldeep*  
**Prof. Kuldeep Singh**  
 Assistant Professor  
 (Structural Engg.)  
 Civil Engineering Department  
 PEC, Chandigarh  
 Ph. : 78373-52591

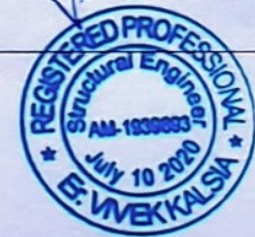
ENGINEER :	<i>Vivek</i> 
PROJECT :	<b>MULTIPURPOSE SHED (180x120)</b> AT ARMY PUBLIC SCHOOL, AMBALA CANTT.(HR)
TITLE :	FOUNDATION EXCAVATION & KEY PLAN
DESIGN BY :	CHECKED BY :
VIVEK	AKASH
DRAWING NO. :	REVISION :
STR-02	R0
DATE :	SCALE :
06.10.2024	N.T.S.

 **BUILTECH ENGINEERING SERVICES**  
 Deals In : Structural Design, DPR, Analysis & Audit

Office - # 3, Jattan Wali Gali, Ambala City (Haryana)  
 +918950117448, +918221828619  
 builtechenggservices@gmail.com



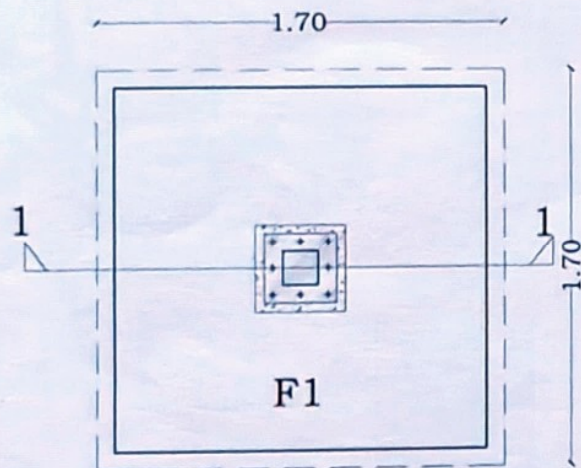
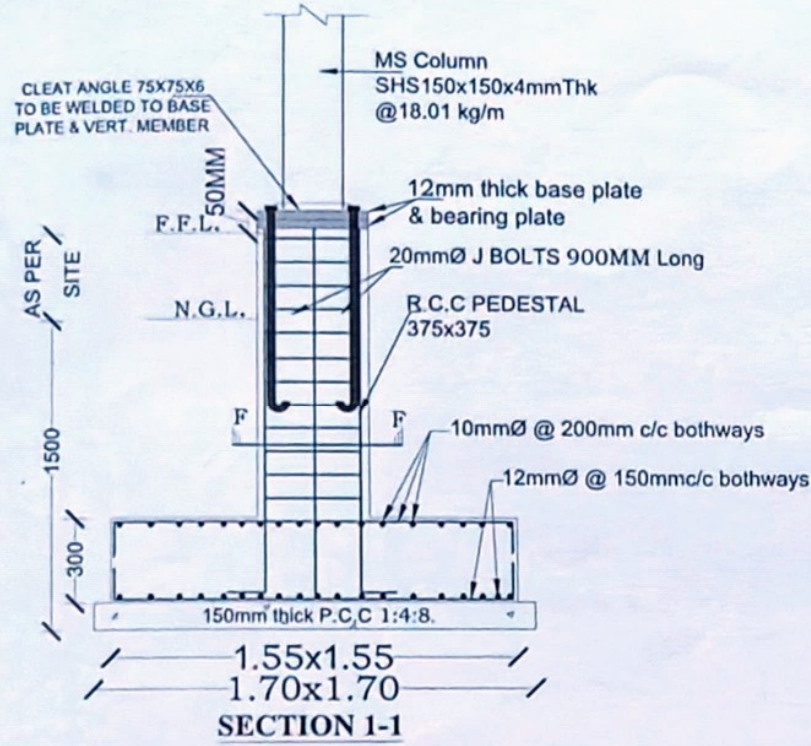

**FOUNDATION F1**

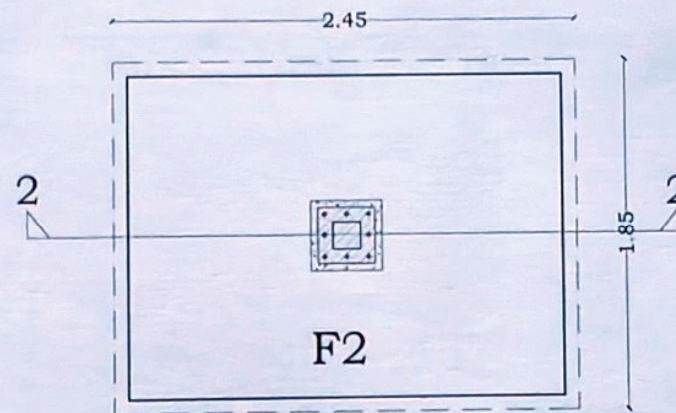
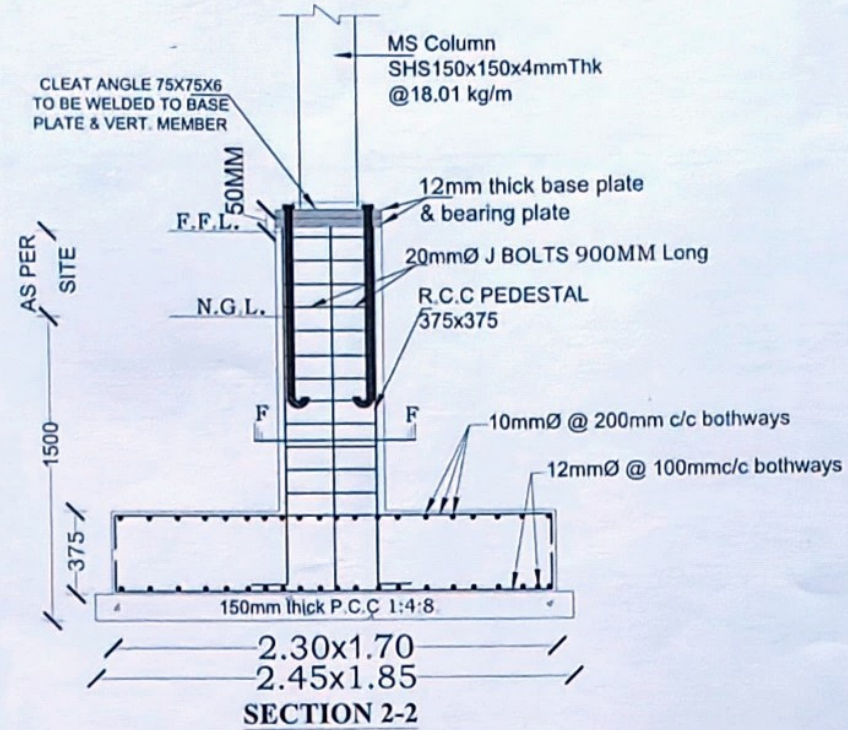

**FOUNDATION F2**

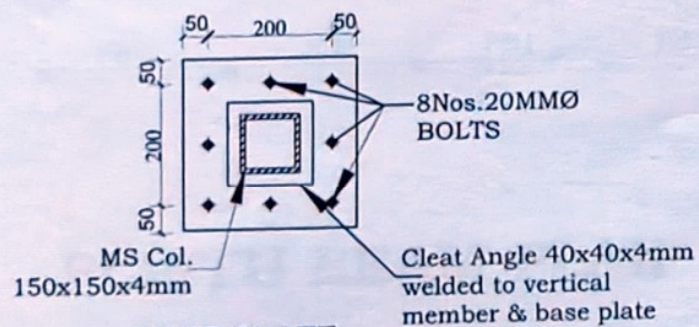

**BASE PLATE  
(300X300X16MM THK.)**

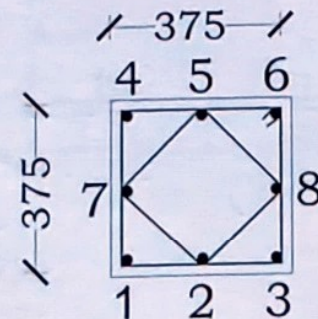

**SECTION AT F-F**  
BAR NO:- 1T08= 16MMØ  
TIES:-2Nos.8MMØ@150MMC/C  
R.C.C PEDESTAL 375X 375

*Kuldeep*  
**Prof. Kuldeep Sonil**  
Assistant Professor  
(Structural Engg.)  
Civil Engineering Department  
PEC, Chandigarh  
Ph. : 78373-52591

ENGINEER :

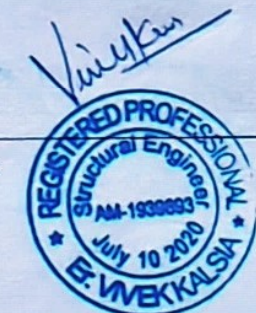

PROJECT :

**MULTIPURPOSE SHED (180x120)**  
AT ARMY PUBLIC SCHOOL,  
AMBALA CANTT.(HR)

TITLE :

FOOTING DETAIL

DESIGN BY :

VIVEK

CHECKED BY :

AKASH

DRAWING NO. :

STR-03

REVISION :

R0

DATE :

06.10.2024

SCALE :

N.T.S.



**BUILTECH ENGINEERING SERVICES**  
Deals In : Structural Design, DPR, Analysis & Audit

Office - # 3, Jattan Wali Gall, Ambala City (Haryana)  
+918950117448, +918221828619  
bultechenggservices@gmail.com

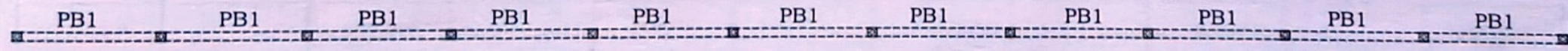
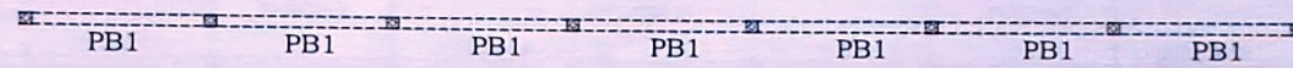
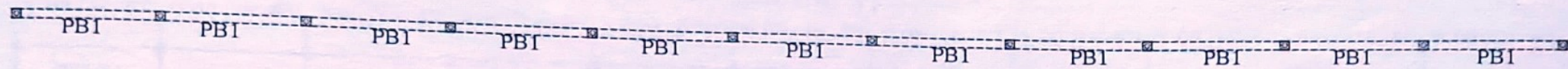

# PLINTH BEAM PLAN

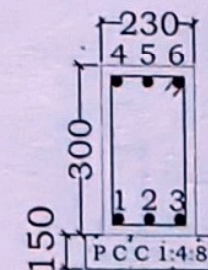

BAR NO: 1T06 = 16MMØ  
 STPS : 2L-8mmØ @ 6" c/c  
 PB-1

*Kuldeep*  
 Prof. Kuldeep Singh  
 Assistant Professor  
 (Structural Engg.)  
 Civil Engineering Department  
 PEC, Chandigarh  
 Ph. : 78373-52591

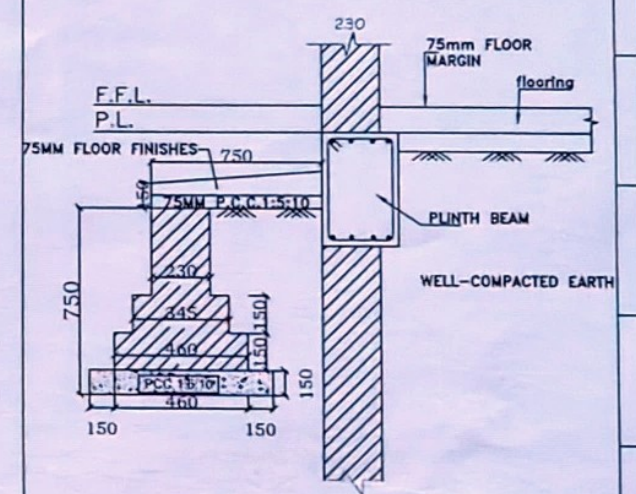

SECTION THROUGH PERIPHERAL PLINTH BEAMS SHOWING TOE WALL

ENGINEER :   
*Vivek*

PROJECT :  
**MULTIPURPOSE SHED  
 (180x120) AT ARMY  
 PUBLIC SCHOOL,  
 AMBALA CANTT.(HR)**

TITLE :  
 PLINTH BEAM PLAN

DESIGN BY : VIVEK	CHECKED BY : AKASH
----------------------	-----------------------

DRAWING NO. : STR-04	REVISION : R0
-------------------------	------------------

DATE : 06.10.2024	SCALE : N.T.S.
----------------------	-------------------

**BUILTECH ENGINEERING SERVICES**  
 Deals In : Structural Design, DPR, Analysis & Audit

Office - # 3, Jattan Wali Gali, Ambala City (Haryana)  
 +918950117448, +918221828619  
 builtechenggservices@gmail.com

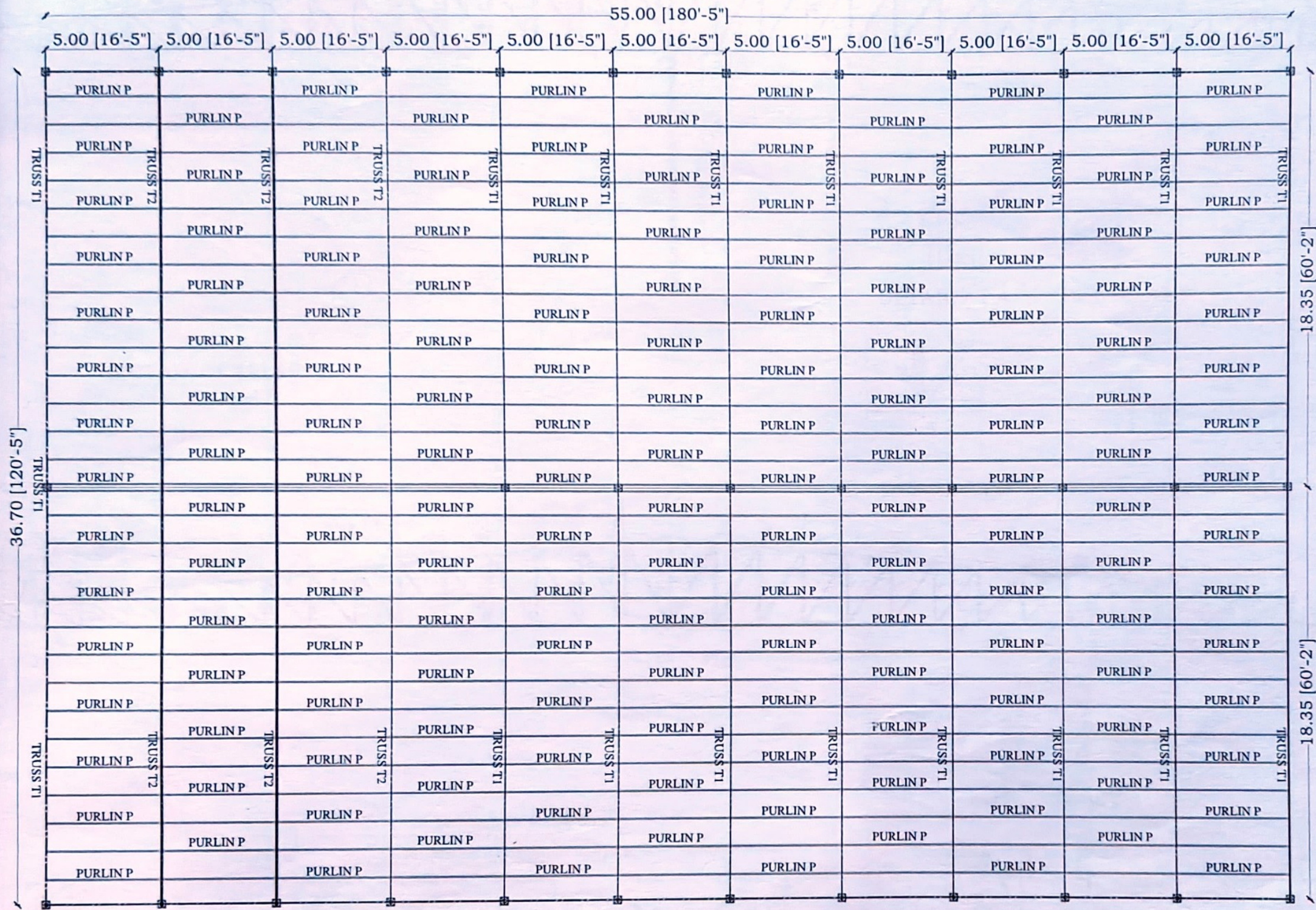

**TOP PLAN OF TRUSS**

*Kuldeep*  
**Prof. Kuldeep Sonni**  
 Assistant Professor  
 (Structural Engg.)  
 Civil Engineering Department  
 PEC, Chandigarh  
 Ph. : 78373-52591

ENGINEER :

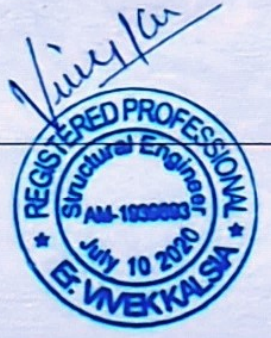

PROJECT :

**MULTIPURPOSE SHED (180x120)**  
 AT ARMY PUBLIC SCHOOL,  
 AMBALA CANTT.(HR)

TITLE :

PLAN OF TRUSS

DESIGN BY :

VIVEK

CHECKED BY :

AKASH

DRAWING NO. :

STR-05

REVISION :

R0

DATE :

06.10.2024

SCALE :

N.T.S.



**BUILTECH ENGINEERING SERVICES**

Deals In : Structural Design, DPR, Analysis & Audit

Office - # 3, Jattan Wali Gali, Ambala City (Haryana)  
 +918950117448, +918221828619  
 builtechenggservices@gmail.com

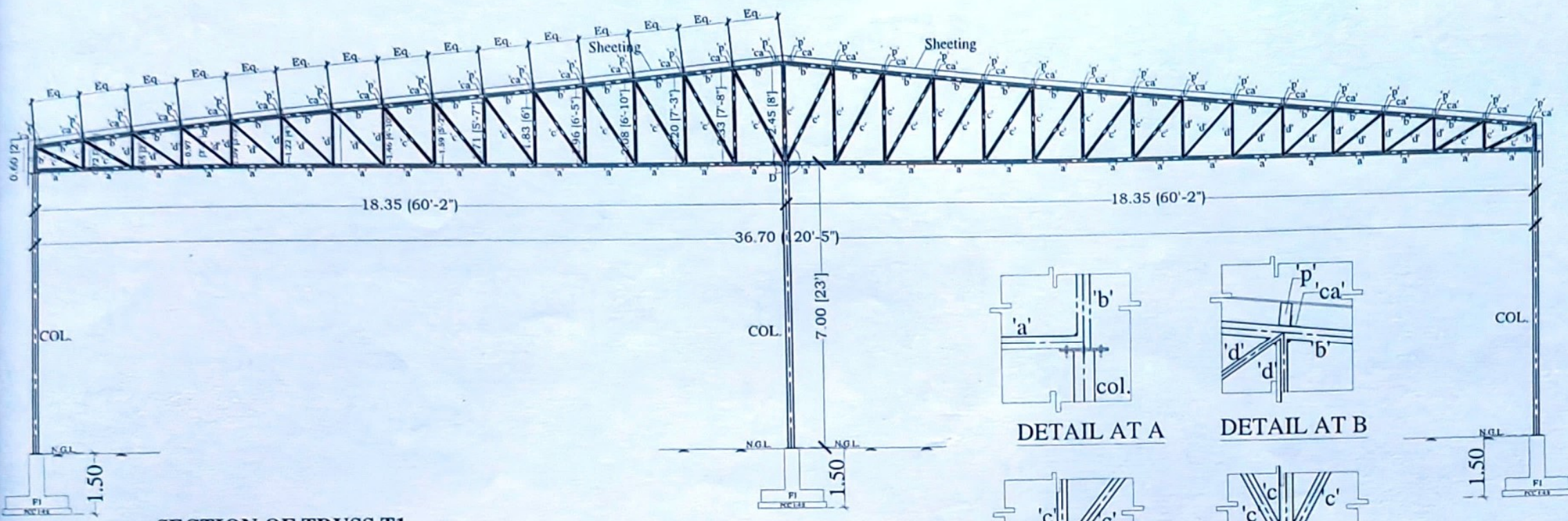

SECTION OF TRUSS T1

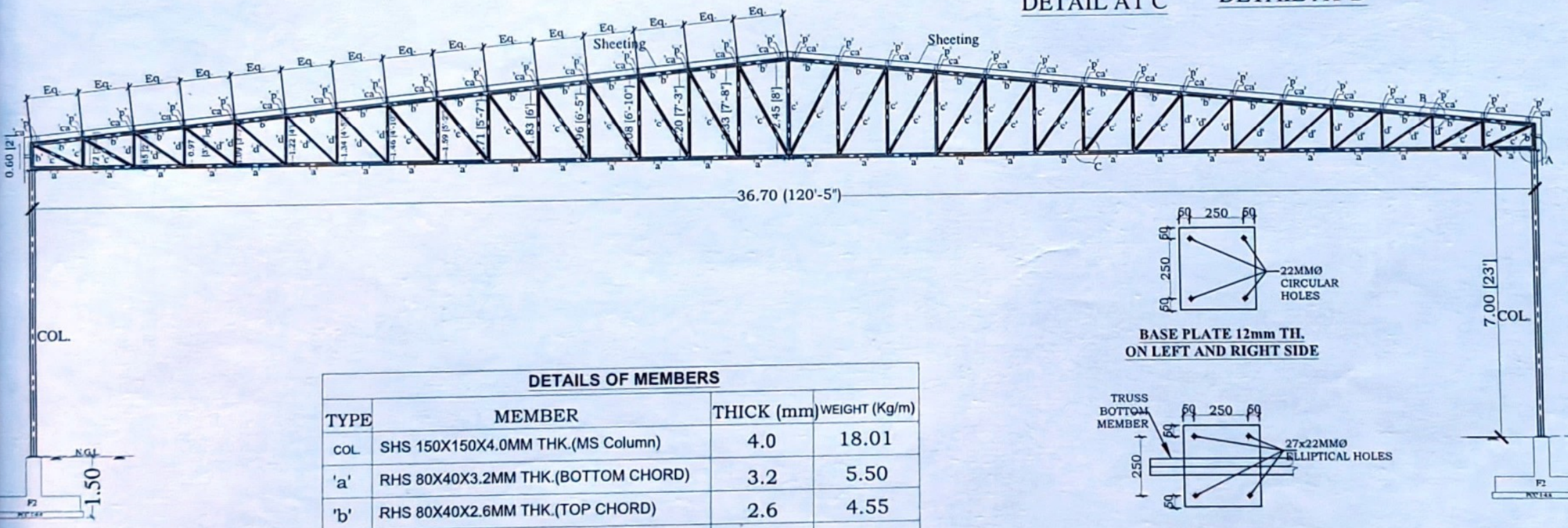
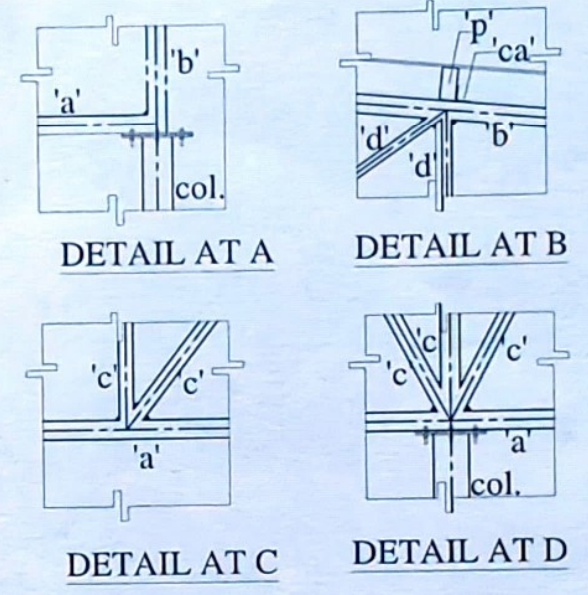

SECTION OF TRUSS T2

DETAILS OF MEMBERS			
TYPE	MEMBER	THICK (mm)	WEIGHT (Kg/m)
col	SHS 150X150X4.0MM THK.(MS Column)	4.0	18.01
'a'	RHS 80X40X3.2MM THK.(BOTTOM CHORD)	3.2	5.50
'b'	RHS 80X40X2.6MM THK.(TOP CHORD)	2.6	4.55
'c'	SHS 60X60X3.2MM THK.(STRUTS & TIES)	3.2	5.50
'd'	SHS 40X40X3.2MM THK.(STRUTS & TIES)	3.2	3.49
'e'	RHS 122X61X3.60MM THK.(BOTTOM CHORD)	3.6	9.67
'f'	RHS 145X82X4.8MM THK.(TOP CHORD)	4.8	15.92
'p'	RHS 140X70X4.0MM THK.(PURLIN)	4.0	12.50
'ca'	ISA 65X65X5.0MM THK.(CLEAT ANGLE)	4.0	4.90

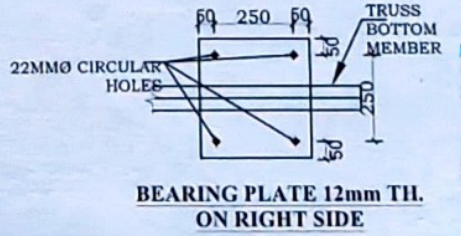
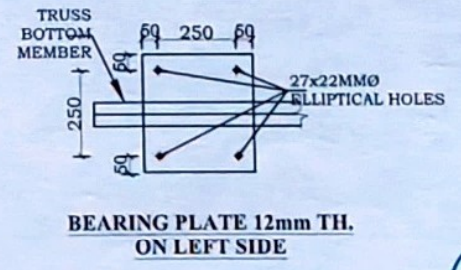
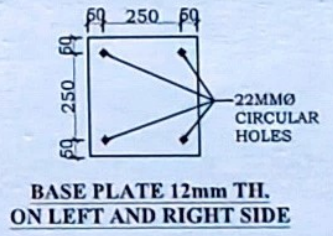

*Kuldeep*  
**Prof. Kuldeep Sonni**  
 Assistant Professor  
 (Structural Engg.)  
 Civil Engineering Department  
 PEC, Chandigarh  
 Ph. : 78373-52591

NOTES:-

1. STRUCTURAL STEEL SHALL BE CONFORMED TO IS 226.
2. WELDING SHALL BE CONFORMED TO IS 816
3. FABRICATION & ERRECTION SHALL BE IN ACCORDANCE TO IS 800
4. DIMENSIONS ARE TO BE READ & NOT TO BE SCALED OFF
5. ALLWELDS SHALL BE 6MM THICK.
6. GRADE OF CONCRETE SHALL BE M25.

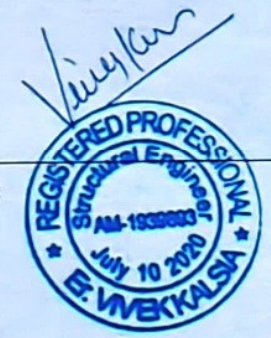

ENGINEER :

PROJECT :

**MULTIPURPOSE SHED (180x120)**  
 AT ARMY PUBLIC SCHOOL,  
 AMBALA CANTT.(HR)

TITLE :

TRUSS SECTIONAL DETAILS

DESIGN BY :

VIVEK

CHECKED BY :

AKASH

DRAWING NO. :

STR-06

REVISION :

R0

DATE :

06.10.2024

SCALE :

N.T.S.

**BUILTECH ENGINEERING SERVICES**  
 Deals In : Structural Design, DPR, Analysis & Audit

Office - # 3, Jattan Wail Gali, Ambala City (Haryana)  
 +918950117448, +918221828619  
 builtechenggservices@gmail.com